

Electric Fuel Pumps

Product overview for universal applications

Vehicle/application:	Product:	Electric fuel pump
Various	Pierburg No.:	(E1F) 7.21440.51.0/.53.0/.63.0/.68.0/.78.0
		(E1S) 7.21088.62.0
		(E2T) 7.21287.53.0; 7.21538.50.0; 7.21565.70.0/.71.0
		(E3T) 7.21659.53.0/.70.0/.72.0
		(E3L) 7.00228.51.0; 7.22156.50.0/.60.0; 7.28217.51.0; 7.28242.01.0

Many customer inquiries reaching our engineering hotline are concerned with the technical data of our fuel pumps for small series or custom applications.

In order to provide some decision guidance with respect to a fuel pump suited for your purposes, please find on the following pages a number of universal pumps from our product line.

These pumps provide a well proven solution in many cases.

For example:

- as a replacement for mechanical fuel pumps where the original pump is no longer available as a replacement (old-/young-timers)
- as a fuel pre-pump for Diesel or Otto engines
- as a temporary solution for repairs where a special replacement is not available
- as an additional pump which is additionally switched on depending on demand (failure of the main fuel pump)
- as a refilling or supply pump in refilling systems, additional tanks or heating systems
- as an additional pump for tuning and racing applications



Information on fuel systems for *injection engines* (for example, pump types E2T or E3T) is provided in our brochure "Service Tips and Information - Fuel supply for engines with Fuel Injection Systems".

Installation and diagnosis related notes especially in the case of *retrofitting* with electric fuel pumps are provided in the brochure "Service Tips and Information - Fuel Systems - Components and solutions for universal applications".

Models

In the case of today's modern designs of electric fuel pumps, the pumping stage is seated directly on the shaft of the electric motor.

The fuel passes through the fuel pump thereby simultaneously cooling and "lubricating" it.

Advantages:

- Fewer moving parts
- Compact design
- Small outside dimensions

Depending on the way in which the fuel pump is accommodated in the vehicle a difference is made between *in-tank* and *in-line* pumps.

For the pumping stage there exist different designs. A rough differentiation is made between *flow pumps* and *positive displacement pumps*.

• **Flow pumps**

In the case of flow pumps the fuel is moved due to the centrifugal force of a rotor. Such pumps are capable of producing lower pressures only (0.2 to 3 bar) and are used either as the pre-stage in a two-stage pump, respectively as a pre-stage pump.

The fuel passes through the flow pump without the need for flaps and valves. For this reason, during standstill of the pump, the fuel may potentially flow backwards through the flow pump.

Flow pumps are not self-priming, i.e. they must always be placed below the liquid level within the fuel tank (maximum suction height 0 mm).

Side channel pumps belong to the category of the flow pumps.

• **Positive displacement pumps**

In positive displacement pumps the fuel is pumped through sealed-off volumes.

Such pumps are used in the case of higher system pressures (up to approximately 6.5 bar) as they prevail in conventional injection systems, for example.

Except for design related leaks, the fuel cannot flow through the positive displacement pump in the reverse direction even when the pump is at standstill.

Toothed ring pumps, sliding vane pumps, roller vane pumps and screw pumps belong to the category of positive displacement pumps.

Positive displacement pumps are self-priming to a very limited extent, i.e. they should be mounted below the liquid level of the fuel tank (maximum suction height 500 mm).

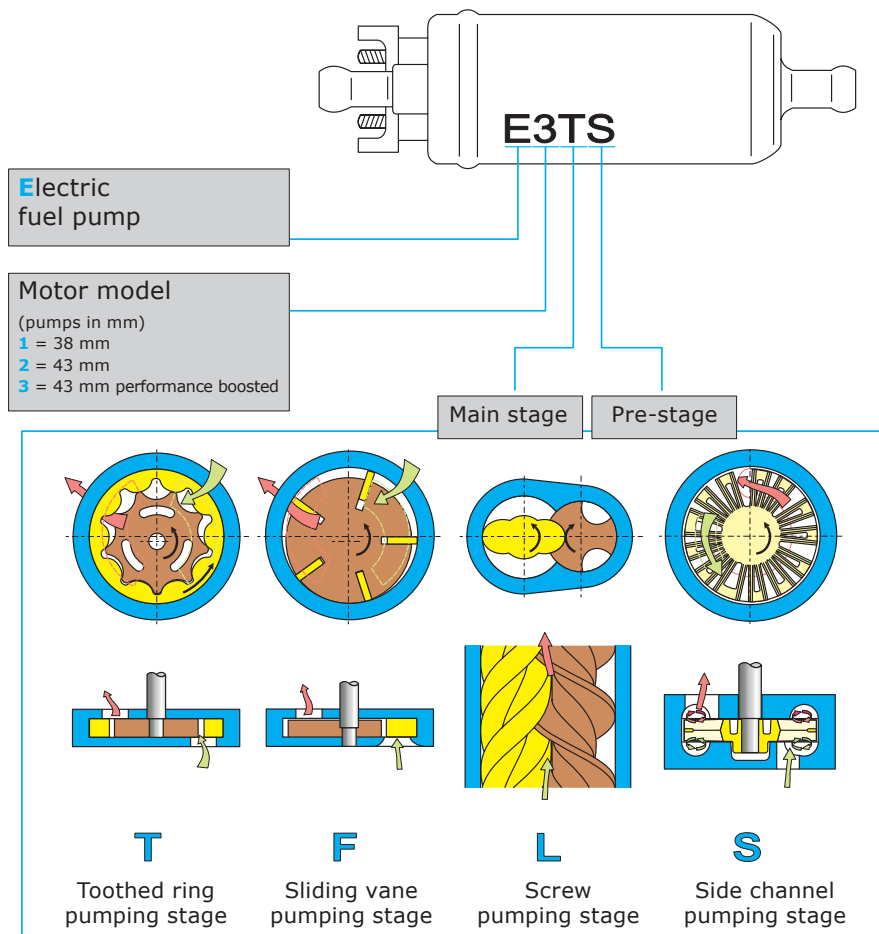

Please note:

The curves provided in the following are "typical" pump characteristics and serve only the purpose of providing a rough overview.

The pumping characteristic of a pump must not *precisely* correspond to this curve.

Typical pump characteristics will only be attained after a sufficient running-in time has elapsed.

! For safety reasons, all work on the fuel system must only be done by suitably qualified personnel.

E1F (Sliding vane pump)

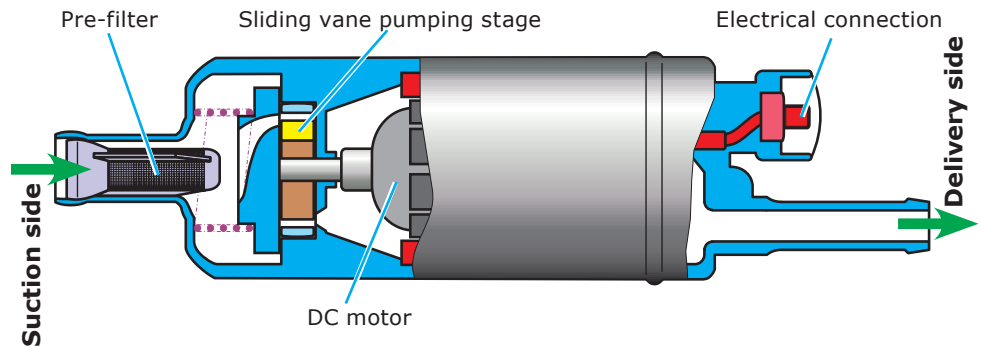
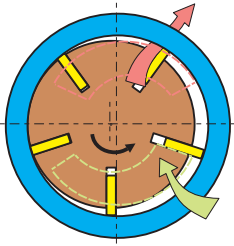

E1S (Side channel pump)

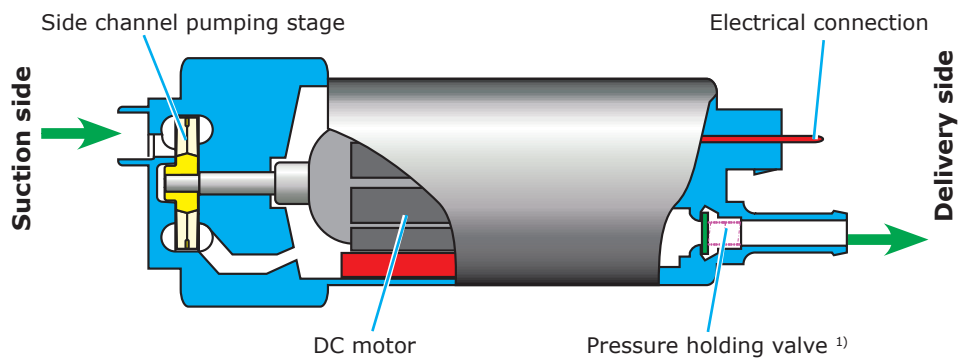
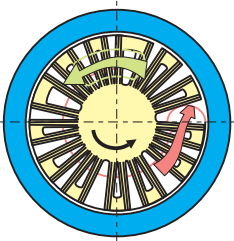

E3L (Screw pump)

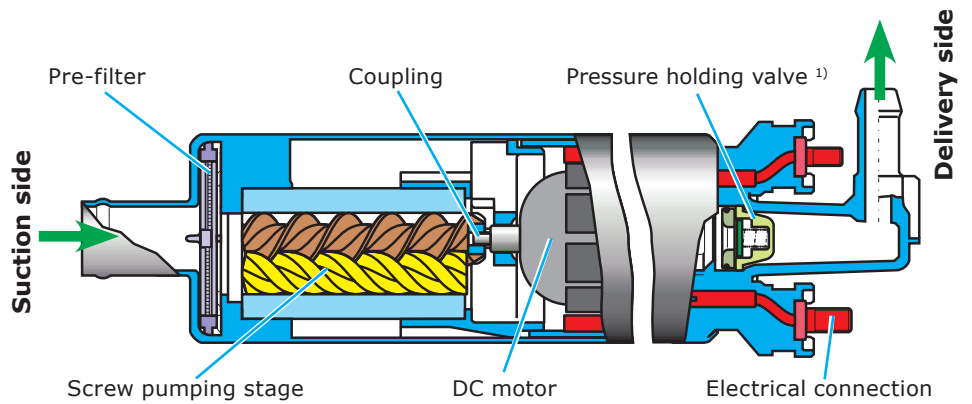
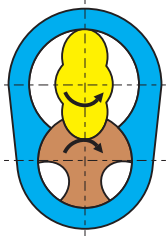

E2T/E3T (Toothed ring pump)

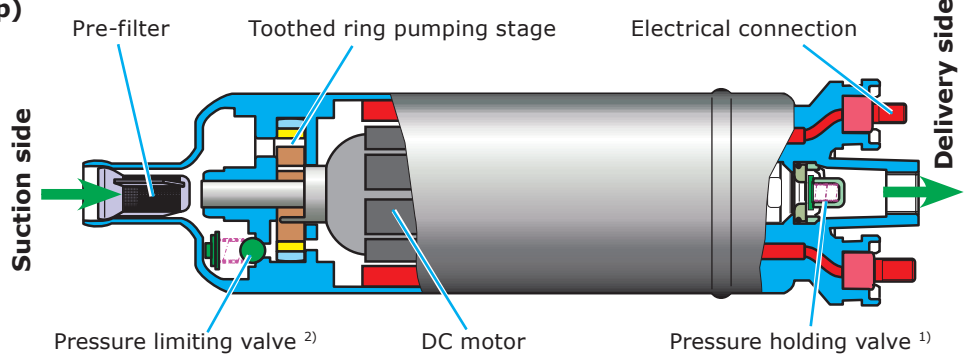
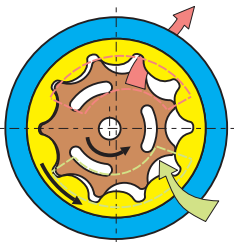

¹⁾ The pressure holding valve maintains a holding pressure within the fuel system even with the ignition switched off.

²⁾ The pressure limiting valve opens when the pressure within the fuel pump increases to unacceptably high levels.

Model E1F



A frequently used pump is the model E1F. This is an in-line positive displacement pump with a sliding vane pumping stage and it is suited for system pressures of 0.1 to 1.0 bar. This pump is available for 12 and 24 Volt operation and is inserted into the line. For 6 Volt operation (in the case of old-timers, for example) we recommended the E1F No. 7.21440.53.0. In the case of 6 Volt operation, pressure and volume flow are reduced approximately to the half.

- ⚠ Maximum suction height: 500 mm (in the case of filled lines)
- ⚠ When installing an electric fuel pump (12 Volt) instead of a mechanical fuel pump, we recommend, for safety reasons, the installation of a safety shutdown facility (4.05288.50.0)! See → "Service information SI 0016A".

Pierburg No.	Curve	Nominal voltage	Stat. pressure at Q=0 l/h	Volume flow	System pressure	Installation, resp. connection dimensions (see Fig. below)					Current consumption
						at					
						Ø A	B	C	Ø D	Ø E	
		[V]	[bar/(psi)]	[l/h]	[bar/(psi)]	[mm]					[A]
7.21440.51.0	1	12	0.27-0.38 (4-5.5)	95	0.10 (1.5)	38	133.5	84.5	8	8	≤ 2.0
7.21440.53.0	2	12*)	0.44-0.57 (6.3-8.3)	100	0.15 (2.2)	38	133.5	84.5	8	8	≤ 2.05
7.21440.63.0	2	24	0.44-0.57 (6.3-8.3)	100	0.15 (2.2)	38	134.2	84.5	8	8	≤ 1.35
7.21440.68.0	3	24	> 1.85 (> 26.8)	95	1.00 (14.5)	38	139.5	90.5	8	8	≤ 3.0
7.21440.78.0	3	12	> 1.85 (> 26.8)	95	1.00 (14.5)	38	141.5	91.0	8	12	≤ 4.3

*) also is suited for 6 Volt operation

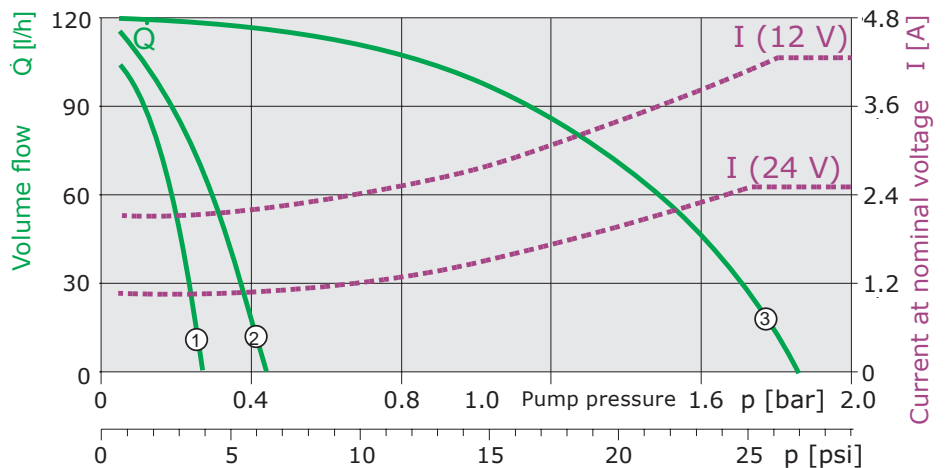
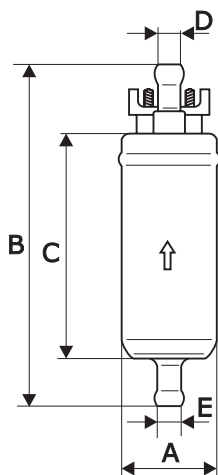

Model E1S



The E1S is offered for installation *within* a fuel tank.

This pump is a flow type pump with a side channel pumping stage for 12 Volt operation.

This pump is preferably used as a pre-pump.

Pre-pumps pump the medium at low pressure in the direction of the main pump.

This prevents the generation of a low-pressure on the suction side of the main pump which might damage the main pump due to cavitation.



Maximum suction height: 0 mm.

The pump must be placed within the medium which is being pumped.

Model E1S pumps can be used up to a volume flow of approximately 220 l/h as a pre-pump.

Pierburg No.	Nominal voltage	Stat. pressure at Q=0 l/h	Volume flow	System pressure	Installation, resp. connection dimensions (see Fig. below)					Current consumption	Max. suction height
					at						
					Ø A	B	C	Ø D	Ø E		
	[V]	[bar/(psi)]	[l/h]	[bar/(psi)]	[mm]					[A]	[mm]
7.21088.62.0	12	-	75	0.24 (3.5)	38	100	75.3	8	19	3	0

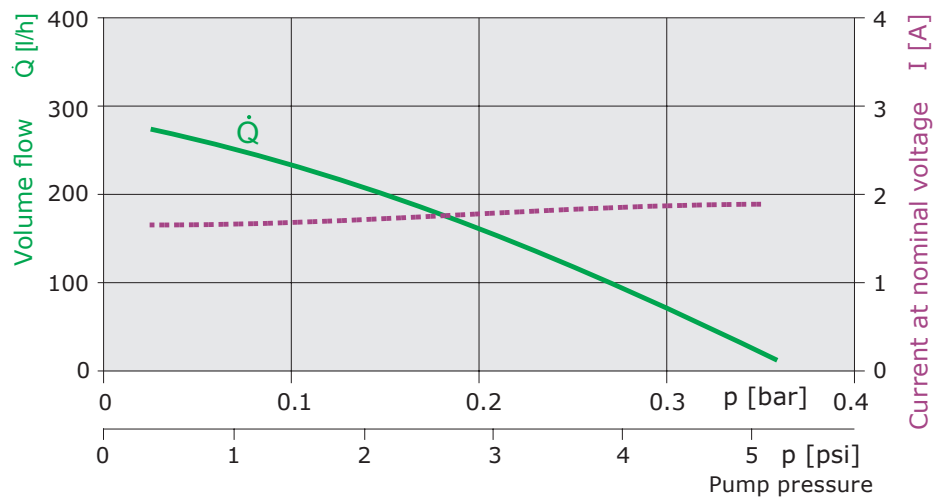
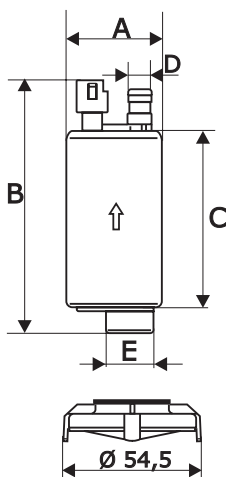

Model E3L



Model **E3L** pumps are in-line pumps with a screw pumping stage.

They perform especially well, are quiet and their current consumption at high pressures is comparatively low.



Maximum suction height: 500 mm (with filled lines)

Pierburg No.	Curve	Nominal voltage	Volume flow	System pressure	Installation, resp. connection dimensions (see Fig. below)					Current consumption
					at	Ø A	B	C	Ø D	
		[V]	[l/h]	[bar/(psi)]	[mm]					[A]
7.00228.51.0	1	13.5	300 - 360	5 (72.5)	43.2	235	175	8	15	< 16
7.22156.50.0	2	13.5	150 - 190	...4 (...58)	43.2	214	156	8	15	< 9.4
7.22156.60.0 ¹⁾	2	13.5	150 - 190	...4 (...58)	52 ²⁾	214	159 ²⁾	8	15	< 9.4
7.28217.51.0	3	12	205 - 275	1.8 (26)	43.5	199,5	156	8	8	2.8 - 6.8
7.28242.01.0	4	13.5	180 - 260	0.5 (7)	43.2	211	156	8	8	< 4.5

1) corresponds to 7.22156.050.0 with rubber jacket

2) dimensions including rubber jacket

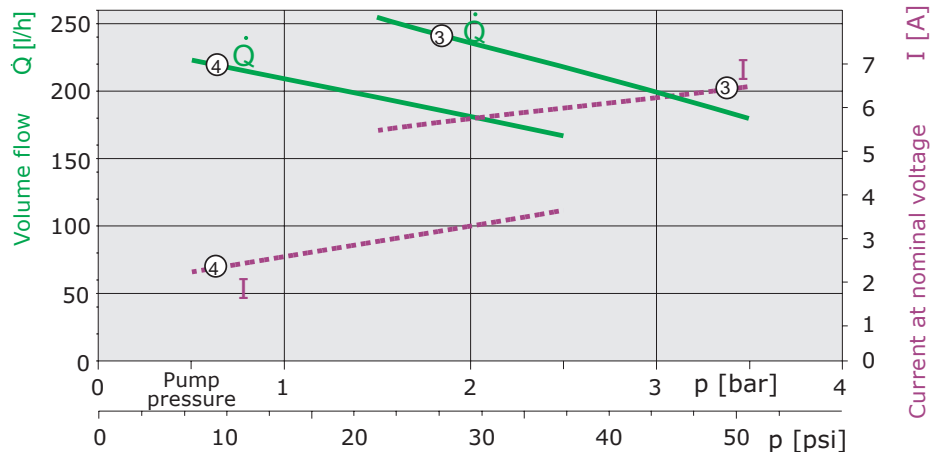
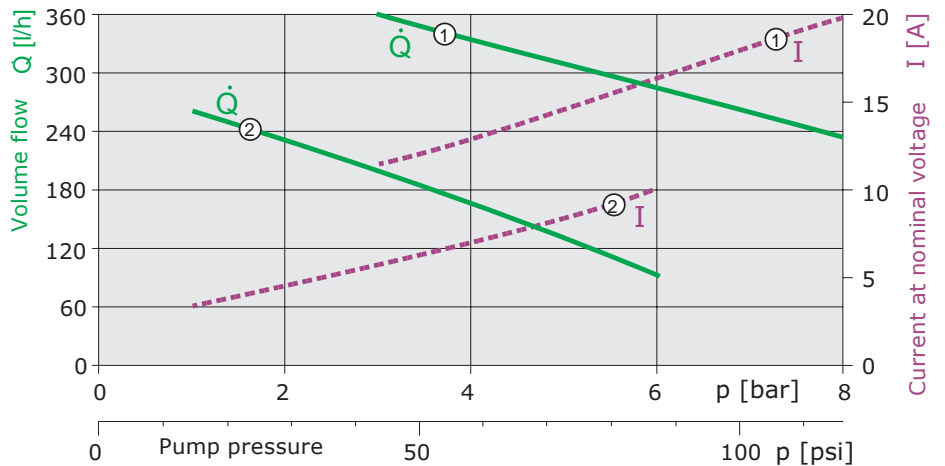
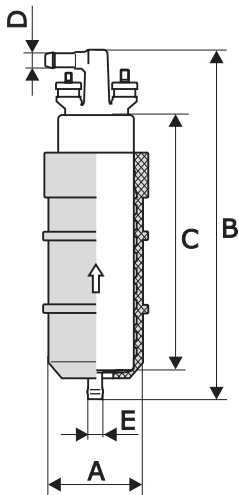

Model E2T/E3T



Model E2T / E3T fuel pumps are self-priming toothed ring pumps and have been designed to handle higher flow rates.

Located on the delivery side is a pressure holding valve, which depending on the model of the pump is either integrated within the pump or is accommodated in exchangeable screw-in fittings.

An integrated pressure limiting valve prevents the occurrence of excessively high pressures and thus possible damage to the fuel system.

The pressure limiting valve is a safety valve only and is not suited for pressure control purposes!



Maximum suction height: 500 mm

The E2T / E3T electric fuel pumps have an outside diameter of 43 mm.

In connection with the rubber jacket supplied with some of the pumps from this line, they are suited for the purpose of replacing fuel pumps of other manufacturers having outside diameters of 52 and 60 mm (see table, dimension "A").

Additionally, the rubber jacket serves the purpose of silencing the pump.

Pierburg No.	Curve	Nominal voltage	Stat. pressure at Q=0 l/h	Volume flow	System pressure	Installation, resp. connection dimensions (see Fig. below)					Current consumption at system pressure
						at	Ø A	B	C	Ø D	
		[V]	[bar/(psi)]	[l/h]	[bar/(psi)]	[mm]					[A]
E2T											
7.21538.50.0	1	12	2.7-5.7 (39-83)	80	1.2 (17)	43	160	110	8	12	< 4.5
7.21287.53.0	2	12	4.5-7.5 (68-109)	100	3.0 (43.5)	52*)	160	115*)	8	12	< 6
7.21565.70.0	2	12	4.5-7.5 (68-109)	100	3.0 (43.5)	52*)	190	115*)	M10x1 A, B	12	< 6
7.21565.71.0	2	12	4.5-7.5 (68-109)	100	3.0 (43.5)	52*)	190	115*)	M10x1 C, B	15	< 6
E3T											
7.21659.53.0	3	12	8.0-12.0 (116-174)	110	6.5 (94)	52*)	178.5	129*)	M10x1 B	15	< 12
7.21659.70.0	3	12	8.0-12.0 (116-174)	110	6.5 (94)	60*)	178.5	129*)	M10x1 D, E	12	< 12
7.21659.72.0	3	12	8.0-12.0 (116-174)	110	6.5 (94)	60*)	178.5	129*)	M10x1 E	15	< 12

*) dimension including rubber jacket

Screw-in fittings

Depending on the model, the fuel pump is equipped on the delivery side with a connection equipped with an M10x1 inside thread. Supplied with these fuel pumps is

one or several screw-in fittings or these have already been pre-assembled (see Table dimension "D" and the key provided below).

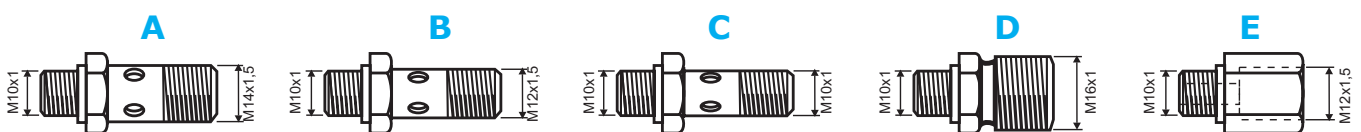

Further information → overleaf

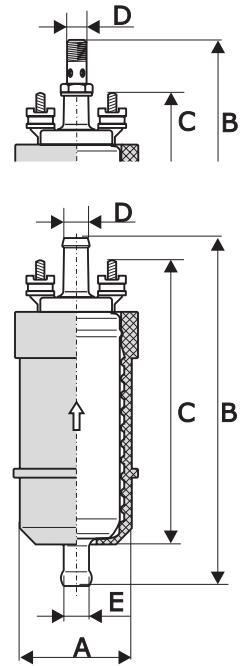
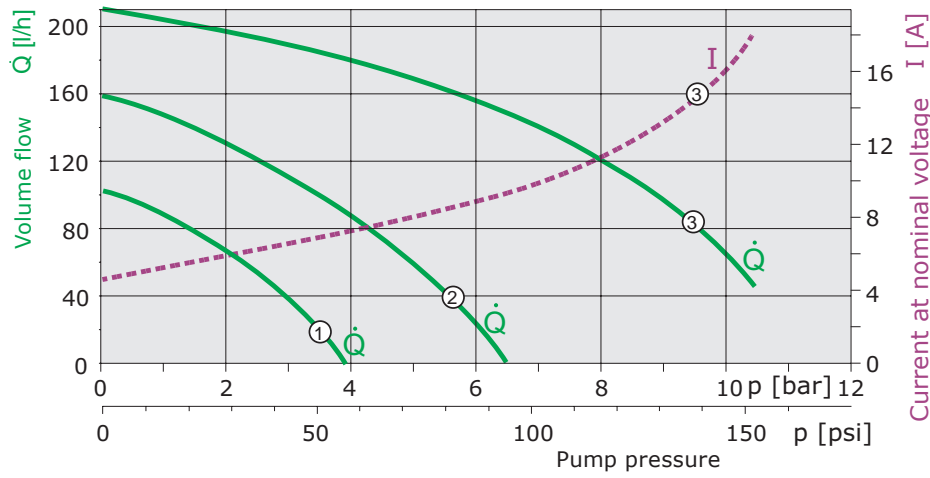
Model E2T/E3T (continued)

Summary

for a quick overview

Pierburg No.	Model	Nominal voltage	Volume flow	System pressure	Current consumption	Remark
			at			
		[V]	[l/h]	[bar/(psi)]	[A]	
7.21440.51.0	E1F	12	95	0.10 (1.5)	≤ 2.0	
7.21440.53.0	E1F	12*)	100	0.15 (2.2)	≤ 2.05	Also suited for 6 Volt operation
7.21440.63.0	E1F	24	100	0.15 (2.2)	≤ 1.35	
7.21440.68.0	E1F	24	95	1.00 (14.5)	≤ 3.0	
7.21440.78.0	E1F	12	95	1.00 (14.5)	≤ 4.3	
7.21088.62.0	E1S	12	75	0.24 (3.5)	3	In-tank pump
7.21538.50.0	E2T	12	80	1.2 (17)	< 4.5	Including rubber jacket
7.21287.53.0	E2T	12	100	3.0 (43.5)	< 6	
7.21565.70.0	E2T	12	100	3.0 (43.5)	< 6	Including rubber jacket
7.21565.71.0	E2T	12	100	3.0 (43.5)	< 6	Including rubber jacket
7.21659.53.0	E3T	12	110	6.5 (94)	< 12	Including rubber jacket
7.21659.70.0	E3T	12	110	6.5 (94)	< 12	Including rubber jacket
7.21659.72.0	E3T	12	110	6.5 (94)	< 12	Including rubber jacket
7.00228.51.0	E3L	13.5	300 - 360	5 (72.5)	< 16	
7.22156.50.0	E3L	13.5	150 - 190	...4 (...58)	< 9.4	
7.22156.60.0	E3L	13.5	150 - 190	...4 (...58)	< 9.4	Including rubber jacket
7.28217.51.0	E3L	12	205 - 275	1.8 (26)	2.8 - 6.8	
7.28242.01.0	E3L	13.5	180 - 260	0.5 (7)	< 4.5	