

GM 283ci, 327ci, 350ci, 400ci w/o Seal Housing

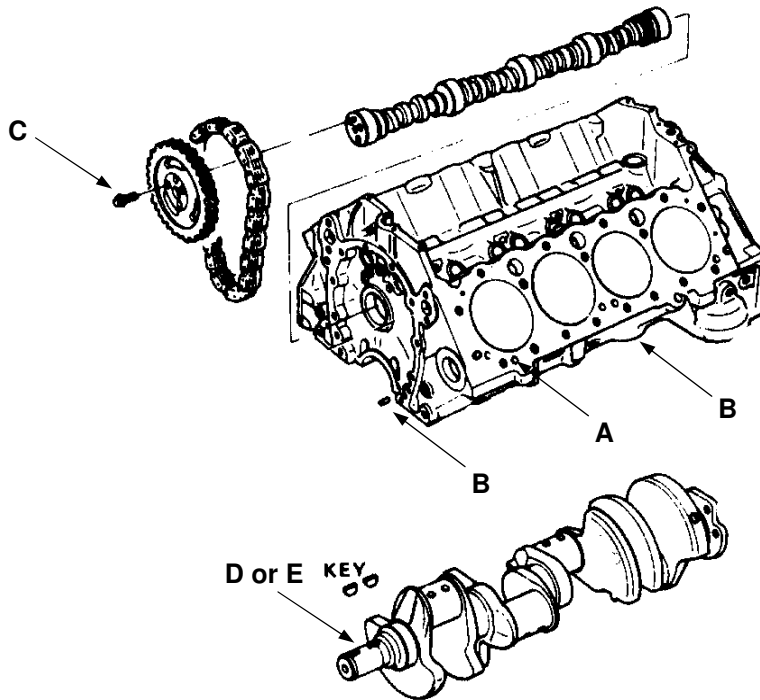

Part # FKC-1			
Location	Qty	Contents	Description
A	4	Head Dowel	.3125 x .565
B	2	Timing Cover / Oil Pump Dowel	.2466 x .630
C	3	Cam Bolt	5/16-18 x 3/4 Cap Screw, Hex Drive
D	1	Woodruff Key	3/16 x 1-3/8
E	2	Woodruff Key	3/16 x 3/4
All components should be assembled per O.E.M. recommendations.			

The "Engine Hardware Finishing Kits" are provided to help eliminate searching for misplaced parts, while providing fresh new parts to meet or exceed O.E.M. specifications.

These kits are researched and designed for the most popular applications. To avoid extra spare parts and cost to the installer, some deviation may occur due to suggestions by nationwide rebuilders and O.E.M. changes in production. We rely on our customers for additional feedback in order to provide you with the most complete part kit available.

For further information, please contact Dura-Bond at:
3200 Arrowhead Dr., Carson City, NV 89706
Phone: (800) 227-8360 Fax: (775) 883-9497
www.dura-bondbearing.com



© 2003 DURA-BOND BEARING COMPANY ALL RIGHTS RESERVED.
NO PORTION OF THIS SHEET MAY BE REPRODUCED WITHOUT OUR EXPRESS WRITTEN PERMISSION.